

Secure Disc

- 60 minutes datamedia protection

For some users the Secure MediaCooler would be too small for their protection needs. A suitable solution would be the fire-resistant safe, Secure Disc, from SecureLine. Ideal for offices and small businesses, the safe offers 60 minutes fire protection, electronic and key locking options and a choice of two sizes. With all these features packed into one safe you may think there is a catch somewhere. But you would be wrong – you really are getting more for your investment. After all, the Secure Disc is from SecureLine!!!

Model

- The Secure Disc is available in two models
- Secure Disc is a dedicated computer media protection cabinet designed to protect a wide range of datamedia (e.g. CD/DVDs)

Locking

- All safes are available with an user friendly electronic pin-code or security key lock

Certification

- Both Secure Disc models are tested and certified to NT Fire 017 60DIS
- Due to the insulated walls and special insert the internal temperature will not raise above 52°C

Additional features

- The insert is equipped with a high quality latch handle which offers an easy opening of the inner compartment and a secure closure
- The compartment latch as well as the hinge are in chromium finish

Design

- The Secure Disc range will complement any user environment and are supplied in a modern two-tone light grey and dark grey
- The data media insert is finished in off white

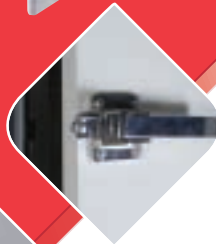

from **Chubb**safes



Secure Disc

Models

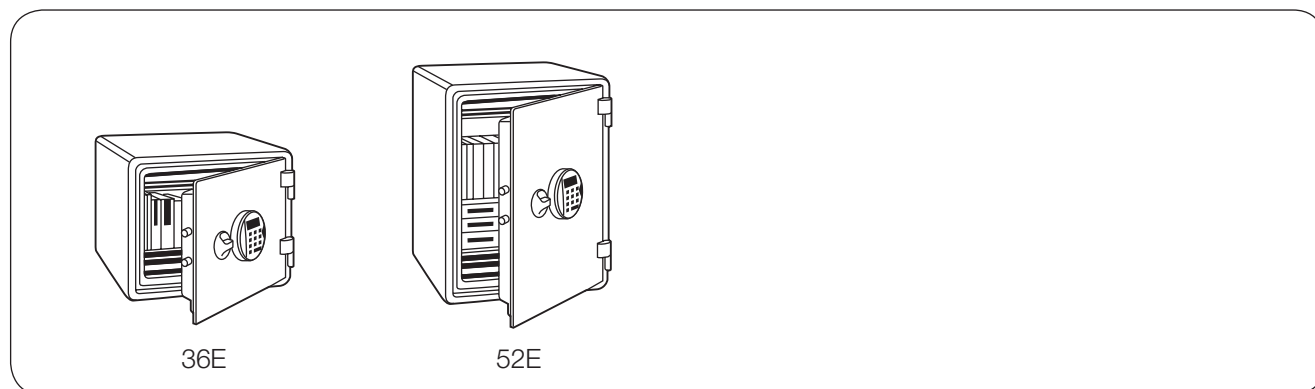

36E

52E

Product data

Key lock

Model	Article No.	External dimensions (mm)			Internal dimensions (mm)			Volume (litres)	Weight (kg)	Shelf (qty)	Fire Rating (mins)
		Height	Width	Depth	Height	Width	Depth				
SDI-36K	SL03820	345	424	458	150	230	195	7	44	N/A	60
SDI-52K	SL03821	520	410	445	320	210	195	13	71	1	60

Electronic lock

Model	Article No.	External dimensions (mm)			Internal dimensions (mm)			Volume (litres)	Weight (kg)	Shelf (qty)	Fire Rating (mins)
		Height	Width	Depth	Height	Width	Depth				
SDI-36E	SL03800	345	424	458	150	230	195	7	44	N/A	60
SDI-52E	SL03801	520	410	445	320	210	195	13	71	1	60

SecureLine policy is one of constant improvement. The above specification may therefore be altered without prior notification.

www.secureline.co.uk

Authorised dealer:



from **Chubb**safes